

GCT 280HBD FLOOR DRAIN SKU:GCT130-001-A000

Fixed height stainless steel floor drain (gully) for tiled, concrete and resin flooring in commercial kitchens, breweries, supermarkets and food processing areas, etc. For applications with higher flow or load class requirements



Specification

Standard (RSA): SANS 51253-1
Standard (EN): EN 1253-1
Floor: Tiles, resin, concrete
Material (EN): 1.4301 (304) or 1.4404 (316)
Max flow (l/s): 11.67
Odour trap: Yes, integral, tamper-proof
Water seal height (mm): 50
Solids basket: Yes
Solids basket volume (l): 2.91
Surface finish: Pickled and passivated, polished
Membrane type: No membrane
Adjustable: No
Load class: L15 to N250
Number of screws: 2 (odour trap)
Gasket: Yes
Gasket material: NBR
Number of inlets: 0
Inlet/s diameter (mm): NA
Outlet direction: Horizontal
Outlet diameter (mm): 110
Minimum height (mm): 376
Body diameter (mm): 282
Overall dimensions (mm): 444 l X 444 w X 376 h
Weight (kg): 118.0

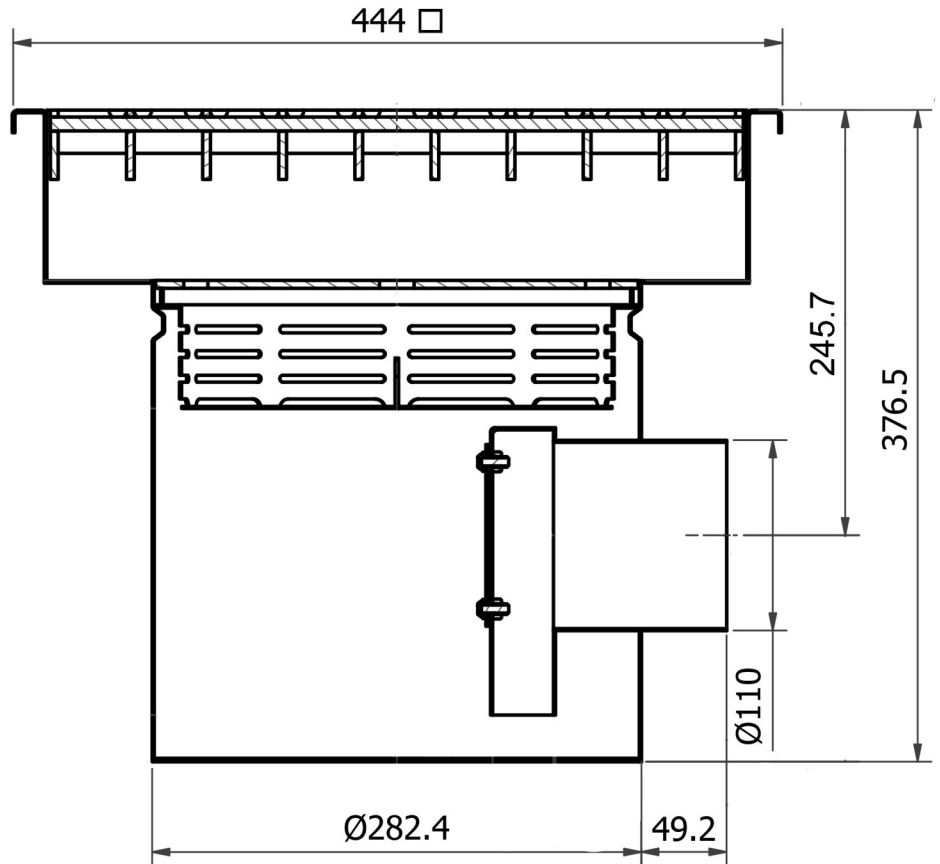

Order Sheet:

Please mark option/s in each box with an X. * (asterisk) indicates special order. If no options are selected the product is supplied as standard.

MATERIAL	CHANNEL EDGE PROFILE	GRATING LOAD CLASS
select one X	select one X	select one X
<input type="checkbox"/> 304	<input type="checkbox"/> PLAIN FOLDED EDGE Edge backfilling with concrete or resin must be done on site to protect against deformation	<input type="checkbox"/> L15 (1500KG)
<input type="checkbox"/> 316*	<input type="checkbox"/> SINGLE SOLID EDGE* A solid stainless steel bar is welded underneath the top channel edge.	<input type="checkbox"/> R50 (5000KG)*
	<input type="checkbox"/> DOUBLE SOLID EDGE* Solid stainless steel bars are welded underneath both the top and bottom channel edge.	<input type="checkbox"/> M125 (12500KG)*
		<input type="checkbox"/> M125 (25000KG)*
Note: A single/ double solid edge provides optimal strength, preventing channel deformation under heavy loads. See GCT Channel Edge Profile.pdf		See GCT Load Classes.pdf

Qty:	Name:	Signature:	Date:	Company:	PO no:
------	-------	------------	-------	----------	--------