

GCT-2G 500 GREASE TRAP SKU:110-001-A000

Stainless steel grease trap (grease interceptor) for free-standing installation at commercial kitchens, restaurants, supermarkets and food processing areas, etc. Designed to treat greasy wastewater from a single fixture with a total flow rate ≤ 1.5 litres/ second.

Specification

Standard (RSA): SANS 10252-2
 Material (EN): 1.4301 (304) or 1.4404 (316)
 Tank wall thickness (mm): 1.2 & 1.5
 Surface finish: Pickled and passivated, polished
 Flow rate (l/s): 1.5
 Max grease capacity (l): 10
 Solids basket: Yes, 1 of
 Basket volume (l): ≈ 7.5
 Basket dimensions (mm): 208 l X 380 w X 221 h
 Total static water volume (l): ≈ 38
 No. of lids: 1
 Lid seal: Yes, EPDM
 Lid sealing mechanism: Fasteners
 Lids load class: None (non-trafficable lid)
 Inlet/ Outlet diameter (mm): 50.8
 Overall dimensions (mm): 600 l X 414 w X 461 h
 Height from bottom to inlet centre (mm): 319
 Height from bottom to outlet centre (mm): 269
 Weight (kg): 15.0

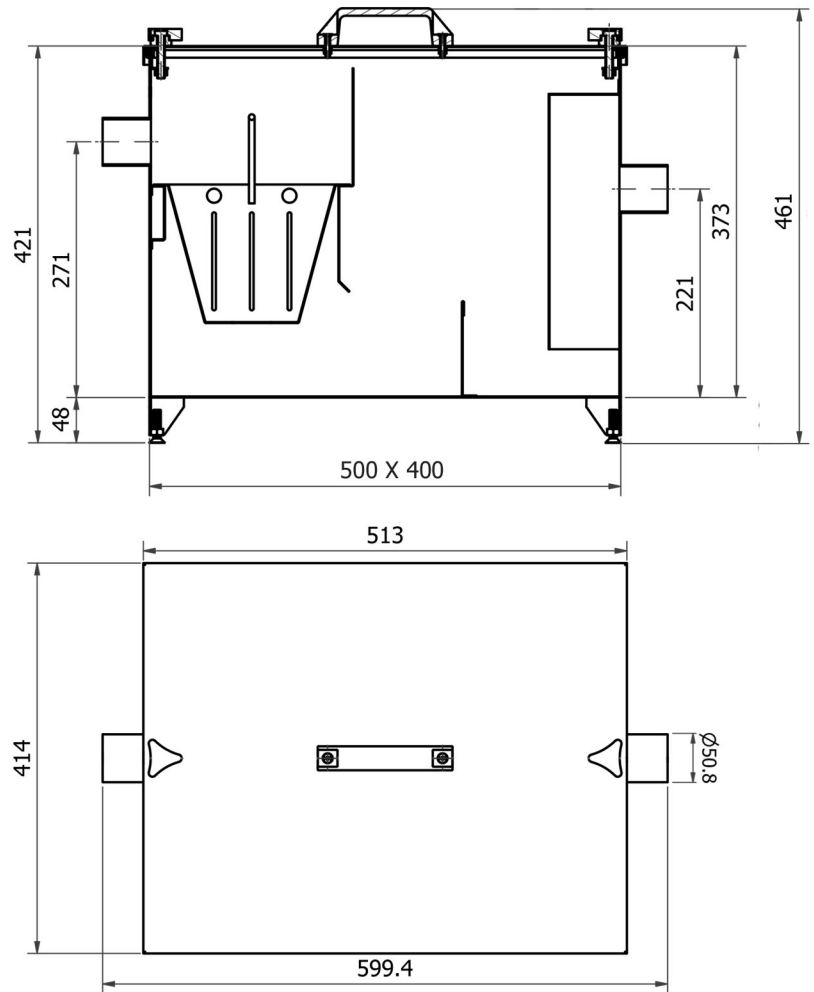

Order Sheet:

Please mark option/s in each box with an X. * (asterisk) indicates special order. If no options are selected the product is supplied as standard.

MATERIAL	LEGS	INLET/OUTLET SIZE
select one X	select one X	select one X
<input type="checkbox"/> 304 <input type="checkbox"/> 316*	<input type="checkbox"/> YES <input type="checkbox"/> NO*	NOT APPLICABLE
Note: Legs are manufactured with adjustable feet.		

Qty:	Name:	Signature:	Date:	Company:	PO no:
------	-------	------------	-------	----------	--------