

GCT 125HA FLOOR DRAIN SKU:156-001-A000

Adjustable (telescopic) stainless steel floor drain (gully) for tiled flooring in small kitchens, cold rooms, washrooms and toilet areas, etc. For applications with liquid membrane waterproofing systems.

Specification

Standard (RSA): SANS 51253-1
Standard (EN): EN 1253-1
Floor: Tiles
Material (EN): 1.4301 (304) or 1.4404 (316)
Max flow (l/s): 1.25
Odour trap: Yes, integral, tamper-proof
Water seal height (mm): 50
Solids basket: No
Solids basket volume (l): NA
Surface finish: Pickled and passivated, polished
Membrane type: Liquid membrane
Adjustable: Yes
Height adjustment (mm): 2 to 20
Load class: 300KG (K3)
Number of screws: 2 (odour trap)
Gasket: Yes
Gasket material: NBR
Number of inlets: 0
Inlet/s diameter (mm): NA
Outlet direction: Horizontal
Outlet diameter (mm): 50.8
Minimum height (mm): 167
Maximum height (mm): 185
Body diameter (mm): 127
Overall dimensions (mm): 400 l X 400 w X 185 h
Weight (kg): 2.4

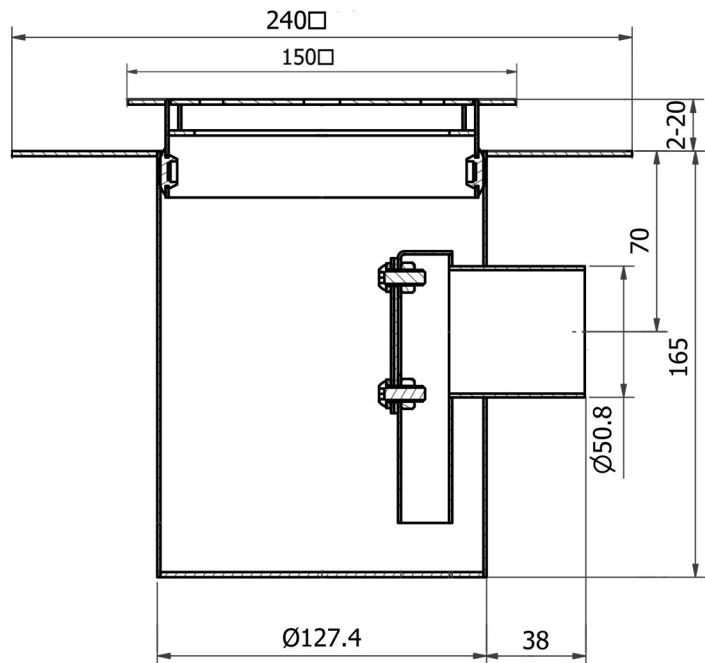
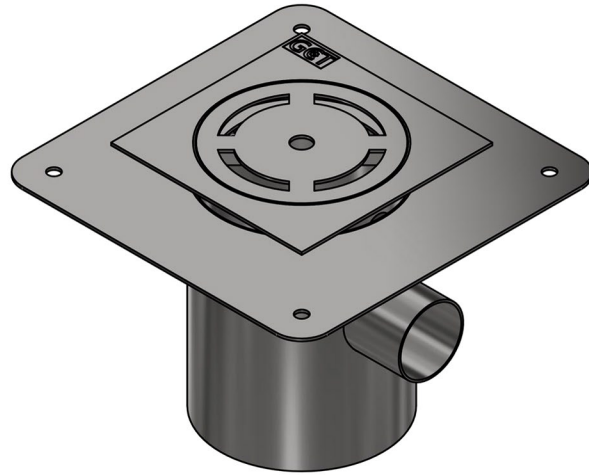

Order Sheet:

Please mark option/s in each box with an X. * (asterisk) indicates special order. If no options are selected the product is supplied as standard.

MATERIAL	FLANGE SHAPE	ODOUR TRAP TYPE
select one X	select one X	select one X
<input type="checkbox"/> 304 <input type="checkbox"/> 316*	NOT APPLICABLE	<input type="checkbox"/> TAMPER-PROOF <input type="checkbox"/> PLUG-IN*
Note: Tamper-proof odour traps (water seals) utilize hex screws and are partially removable with an allen key wrench. Plug-in odour traps utilize a rubber bung and are fully removable by hand.		

Qty:	Name:	Signature:	Date:	Company:	PO no:
------	-------	------------	-------	----------	--------