

GCT-PE SUPERCEPTOR 15™ Class I

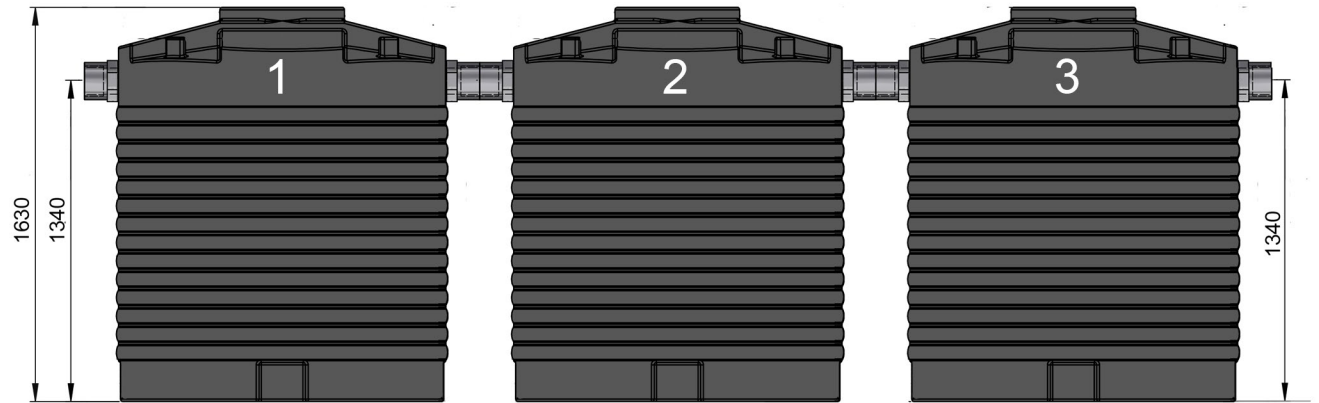

GCT-PE Superceptor 15™ Class I Oil-Water Separator

Features

Class I coalescing separator for separation of all free/non-emulsified oils

- Manufactured from high grade LLDPE, SG 1.6
- One (1) sludge tank [Tank 1]
- One (1) gravity separation tank [Tank 2]
- One (1) coalescing separation tank [Tank 3]
- Auto-shut-off valve with removable coalescing media filter by outlet
- Three (3) easily accessible 450mm diameter covers
- Suitable for below ground or free-standing installations
- Designed in accordance with SANS 50858-1 & 2

Flow Rate: 15L/sec (SANS 50858-1 & EN 858-1, 5PPM, Class I Separator)

Total Liquid Capacity: 5500L

Optimal Oil Storage Capacity: 400L

Max Sludge Capacity: 3000L

Net Weight: ≈ 135KG

General Applications:

Forecourts, petro-chemical plants, fuel depots, substations & medium vehicle wash-bays etc

