

GCT-2G 10L/s

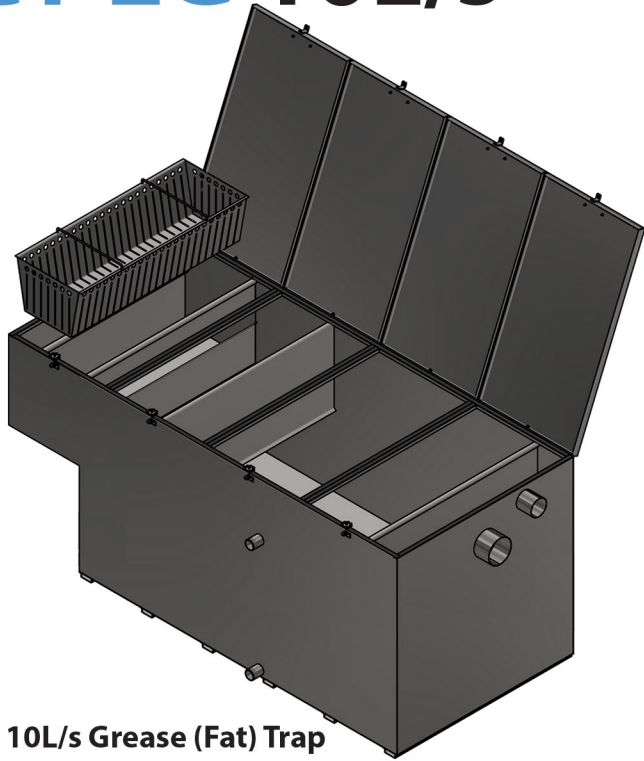

GCT-2G 10L/s Grease (Fat) Trap

Features

- Designed to serve multiple fixtures with a total flow rate ≤ 10 litres/ sec
- Manufactured from 304 stainless steel (316 on special order)
- Four (4) airtight hinged lids [non-trafficable] with EPDM seals & hatch fasteners
- Smooth surfaces to prevent bacteria build up and promote ease of cleaning
- Separated sludge trap & grease trap
- One (1) slotted basket strainer for easy removal of solids
- Fully accessible outlet pipe for rodding
- Compatible with standard plumbing fittings
- Fat take-off port for grease extraction
- Drainage port for emptying the grease trap
- Chamber vent pipe to prevent airlocking
- Suitable for above ground/ free-standing installations
- 2mm (14 gauge) tank
- SANS 10252-2 compliant

Flow Rate: 10L/sec

Max Grease Capacity: ≈ 400 KG

Basket Strainer Volume: ≈ 135 L

Net Weight: 340KG

General Applications:

Hotels, hospitals, food processing plants, prisons & large commercial kitchens etc

